

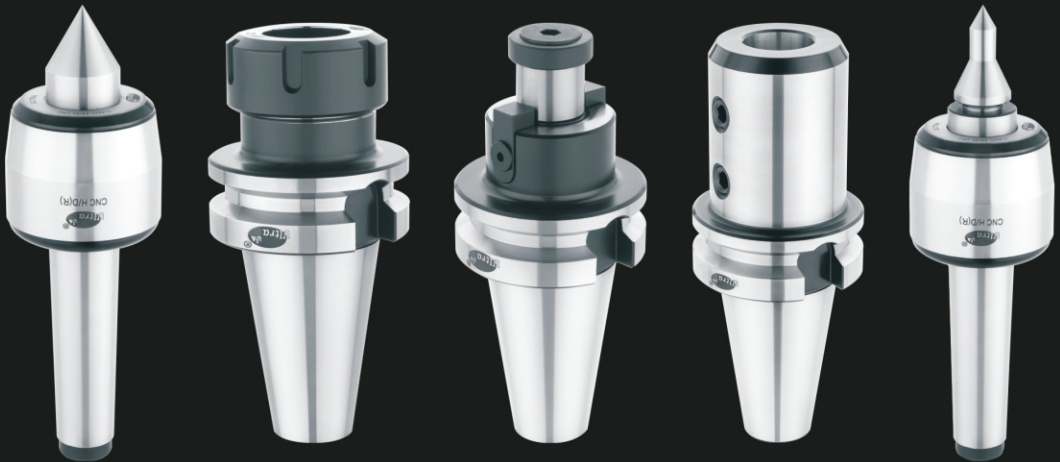

MACHINE TOOL ACCESSORIES

PRODUCT CATALOGUE



FOR THE PEOPLE WHO CARE ABOUT QUALITY



REVOLVING CENTER
CNC H/D R MODEL STUB



REVOLVING CENTER
CNC H/D R MODEL EXTENDED



REVOLVING CENTER
CNC H/D R MODEL PROFILED



REVOLVING CENTER
CNC H/D R MODEL WITH
INTERCHANGEABLE BLUNT



REVOLVING CENTER
CNC SMALL CASING DIA
MEDIUM DUTY



REVOLVING CENTER
CNC H/D R MODEL
INTERCHANGEABLE STUB



REVOLVING CENTER
CNC H/D R MODEL
INTERCHANGEABLE EXTENDED



REVOLVING CENTER
CNC H/D R MODEL
INTERCHANGEABLE PROFILED



REVOLVING CENTER



REVOLVING CENTER CARBIDE



REVOLVING CENTER
EXTRA HEAVY DUTY



REVOLVING CENTER
SUPER EXTRA HEAVY DUTY



BT-ER COLLET CHUCK



BT-STUB MILLING ARBOUR



BT-SIDE LOCK HOLDER



BT-SIDE LOCK HOLDER



BT-MILLING REDUCTION SOCKET



BT-MILLING REDUCTION SOCKET
EXTENDED



ISO COLLET CHUCK



ISO-STUB MILLING ARBOUR



ISO SIDE LOCK HOLDER



ISO MILLING REDUCTION SOCKET



LOCKING DEVICE



CYLINDRICAL SHANK
COLLET CHUCK



CYLINDRICAL SHANK
COLLET CHUCK



CYLINDRICAL SHANK
COLLET CHUCK



MT-ER COLLET CHUCK



EDGE FINDER 4 & 10



EDGE FINDER 10 & 10



TURRET SLEEVE



TURRET SLEEVE



TURRET SLEEVE
IN SIDE MT



ER NUT-UM



ER NUT-HEX



ER NUT M TYPE



PULL STUD



PULL STUD



CNC SOFT JAW



CNC SOFT JAW
L TYPE



CNC T NUT



SPARE POINT CNC H/D R MODEL
INTERCHANGEABLE PROFILED



SPARE POINT CNC H/D R MODEL
INTERCHANGEABLE EXTENDED



SPARE POINT CNC H/D R MODEL
INTERCHANGEABLE STUB



SPARE POINT CNC H/D R MODEL
INTERCHANGEABLE EXTENDED
CARBIDE



SPARE POINT SPECIAL BLUNT
CNC H/D R MODEL
INTERCHANGEABLE POINT



SPARE POINT
CNC H/D R MODEL
INTERCHANGEABLE FEMALE



SPARE POINT
CNC H/D R MODEL
INTERCHANGEABLE FEMALE

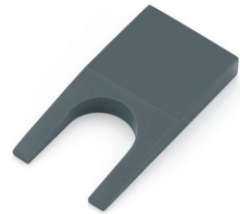

WEDGE



SPARE POINT
CNC H/D R MODEL STUB



SPARE POINT
CNC H/D R MODEL EXTENDED



SPARE POINT
CNC H/D R MODEL PROFILED



CNC DEAD CENTER STUB
WITH DRAW OFF NUT



CNC DEAD CENTER EXTENDED
WITH DRAW OFF NUT



SPANNER MULTI HOOK



SPANNER C HOOK



MT-TANK



DRILL SLEEVE



EXTENSION SOCKET



EXTENSION SOCKET



SPARE POINT



SPARE POINT CARBIDE



DEAD CENTER



DEAD CENTER
CARBIDE TIPPED SPECIAL



LATHE SLEEVE



QUICK CHANGE CHUCK



CO-COLLET



SPLIT SLEEVE
FOR CENTER DRILLS



SPLIT SLEEVE
FOR DRILLS



SPLIT SLEEVE
FOR TAPS



PIPE CENTER
POINTED



PIPE CENTER
BLUNT



DRILL CHUCK ARBOUR

UBT (BT MAS 403)
TAPER AND BOTH FACE CONTACT HOLDER
(After Clamping)

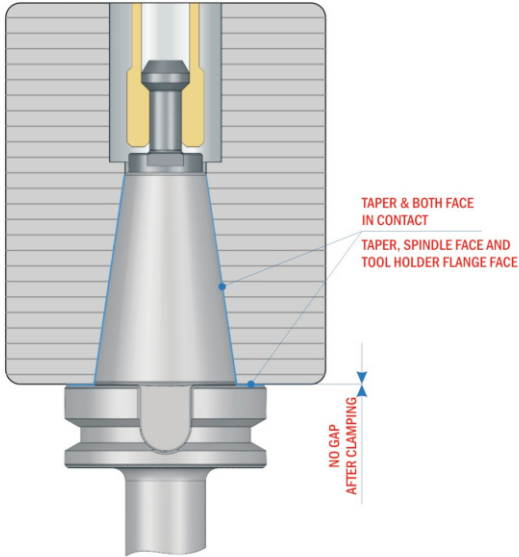

BT (MAS 403) STANDARD HOLDER
(ONLY TAPER CONTACT)
(After Clamping)

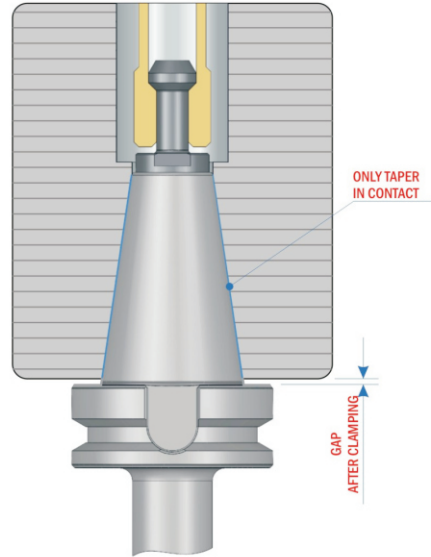

In UBT Tool Holder as mentioned Taper and both faces are in contact, due to which spindle and holder acts as one single unit, this allows a Higher "Radial Rigidity" hence we get good surface Finish and dimensional accuracy while machining, also low vibration at higher speeds which increases Tool Life. Hence UBT Tool Holder has a remarkable significant as compared to Standard Tool Holders.

Note : UBT Tool Holders are only recommended to use in Calibrated UBT Spindle Machines.



MACHINE TOOL ACCESSORIES



**"We Wish To Serve You
Best Quality Machine Tools..."**

Manufactured By:

ULTRA TOOLS INDUSTRY Pvt. Ltd.

Rajkot (Gujarat) INDIA.

